

# M83723/35S Non-Environmental Strain Relief Backshells



Non-Environmental Backshells

Glenair Connector Designator K

MIL-DTL-83723 Series II

**M83723/35S 22 A**  
 Basic Part No. \_\_\_\_\_  
 Dash No. \_\_\_\_\_  
 Finish:  
 A = Black Anodize  
 R = Electroless Nickel

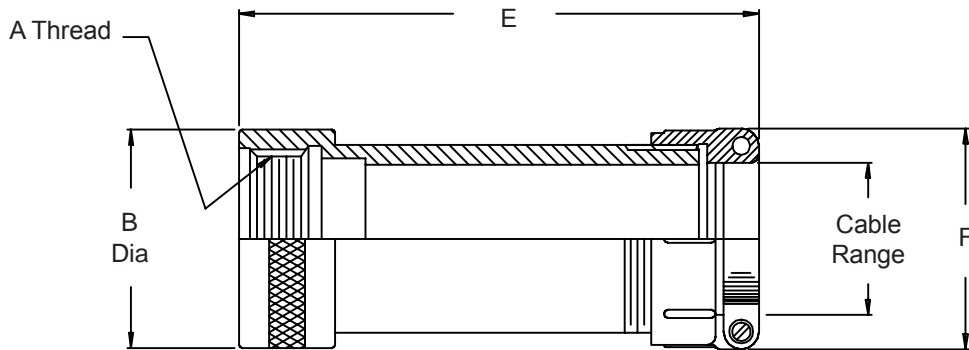

**TABLE I**

Dash No.	Shell Size(s) Ref	A Thread Class 2B	B Dia Max	E Dia	F Max	Cable Range	
						Min	Max
08	8S	.438 - 28 UNEF	.59 (15.0)	1.290 (32.8)	.843 (21.4)	.125 (3.2)	.235 (6.0)
10	10S	.500 - 28 UNEF	.65 (16.5)	1.290 (32.8)	.843 (21.4)	.125 (3.2)	.235 (6.0)
11	10SL	.562 - 24 UNEF	.73 (18.5)	1.290 (32.8)	.906 (23.0)	.170 (4.3)	.287 (7.3)
13	12 & 12S	.625 - 24 UNEF	.77 (19.6)	1.290 (32.8)	1.085 (27.6)	.170 (4.3)	.297 (7.5)
15	14 & 14S	.750 - 20 UNEF	.91 (23.1)	1.368 (34.7)	1.093 (27.8)	.235 (6.0)	.422 (10.7)
16	16	.875 - 20 UNEF	1.03 (26.2)	1.587 (40.3)	1.275 (32.4)	.295 (7.5)	.547 (13.9)
17	16S	.875 - 20 UNEF	1.03 (26.2)	1.430 (36.3)	1.187 (30.1)	.295 (7.5)	.547 (13.9)
18	18	1.000 - 20 UNEF	1.17 (29.7)	1.695 (43.1)	1.475 (37.5)	.325 (8.3)	.610 (15.5)
20	20	1.125 - 18 UNEF	1.30 (33.0)	1.695 (43.1)	1.500 (38.1)	.380 (9.7)	.735 (18.7)
22	22	1.250 - 18 UNEF	1.42 (36.1)	1.695 (43.1)	1.710 (43.4)	.380 (9.7)	.735 (18.7)
24	24	1.375 - 18 UNEF	1.53 (38.9)	1.931 (49.0)	1.719 (43.7)	.500 (12.7)	.922 (23.4)
28	28	1.625 - 18 UNEF	1.80 (45.7)	1.931 (49.0)	2.040 (51.8)	.500 (12.7)	.922 (23.4)
32	32	1.875 - 16 UN	2.04 (51.8)	1.869 (47.5)	2.332 (59.2)	.705 (17.9)	1.235 (31.4)
36	36	2.125 - 16 UN	2.27 (57.7)	1.869 (47.5)	2.312 (58.7)	.725 (18.4)	1.360 (34.5)
40	40	2.375 - 16 UN	2.78 (70.6)	2.875 (73.0)	2.950 (74.9)	.911 (23.1)	1.630 (41.4)

1. For complete dimensions see applicable Military Specification.
2. Metric dimensions (mm) are indicated in parentheses.
3. Cable range is defined as the accommodation range for the wire bundle or cable. Dimensions shown are not intended for inspection criteria.